

# STICK PACK TOOLING CHECKLIST

## EXISTING AUGER MEASUREMENTS

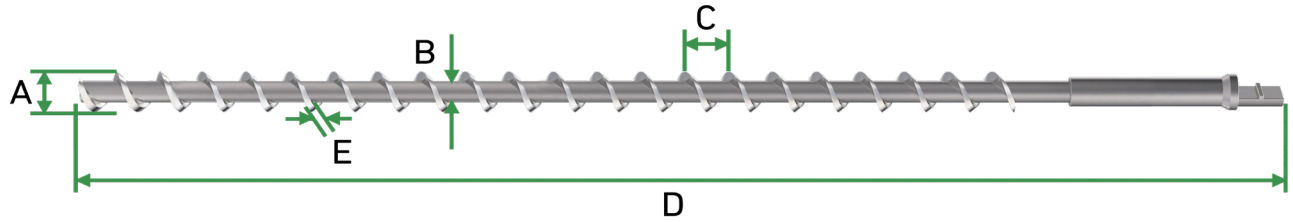

- A. Outside Diameter: \_\_\_\_\_
- B. Rod Diameter: \_\_\_\_\_
- C. Pitch: \_\_\_\_\_
- D. Total Auger Length: \_\_\_\_\_
- E. Flight Thickness: \_\_\_\_\_

## AUGER STEM MEASUREMENTS Fill in only applicable measurements.

Stem Style A

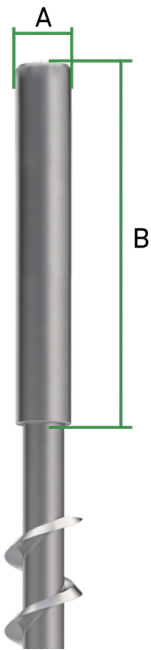

- A. \_\_\_\_\_
- B. \_\_\_\_\_

Stem Style B

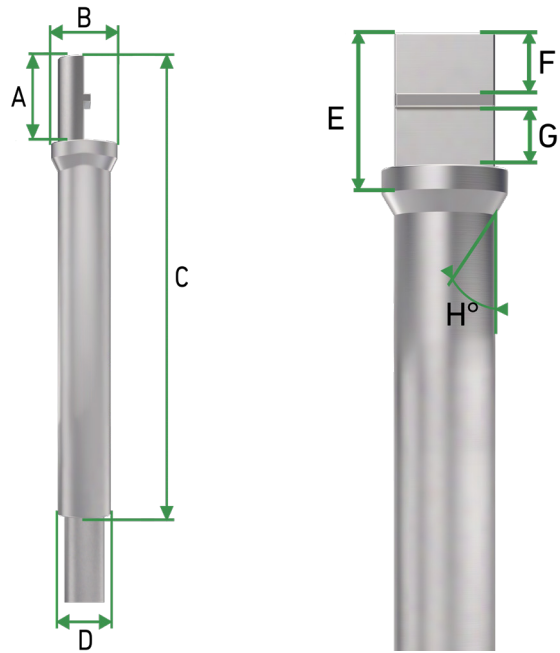

- |          |          |
|----------|----------|
| A. _____ | E. _____ |
| B. _____ | F. _____ |
| C. _____ | G. _____ |
| D. _____ | H. _____ |

4102 Edges Mill Road, Downingtown, PA 19335 USA  
 Phone (610) 524-3350 Fax (610) 363-2821  
 Toll Free: 800-334-1529 info@auger-fab.com  
[WWW.AUGER-FAB.COM](http://WWW.AUGER-FAB.COM)



## AUGER FLIGHTING PROFILE

Check off the style most similar to your existing auger, or provide a detailed picture of your auger.

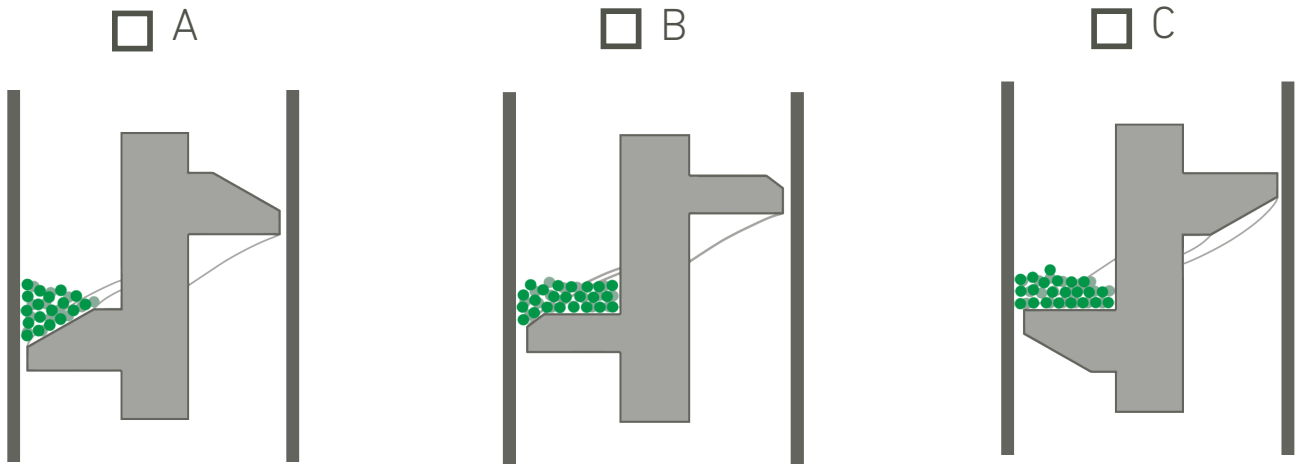

## FUNNEL MEASUREMENTS

- |                               |                             |
|-------------------------------|-----------------------------|
| A. Tube Cut Length: _____     | E. HUD Length: _____        |
| B. Air Purge Length: _____    | F. HUD Height: _____        |
| C. Flat Length: _____         | G. HUD Hole Distance: _____ |
| D. Total Funnel Length: _____ | H. HUD Hole Diameter: _____ |
| Tube Inner Diameter: _____    | Tube Outer Diameter: _____  |

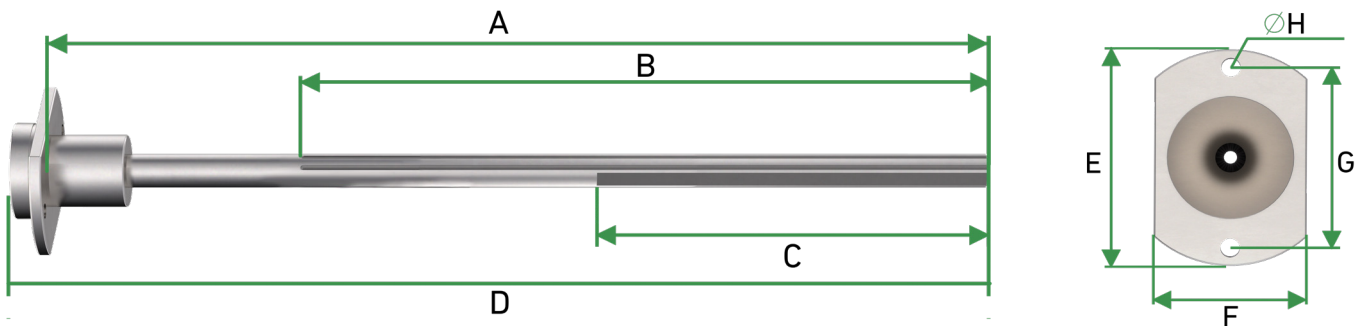

4102 Edges Mill Road, Downingtown, PA 19335 USA  
 Phone (610) 524-3350 Fax (610) 363-2821  
 Toll Free: 800-334-1529 info@auger-fab.com  
[WWW.AUGER-FAB.COM](http://WWW.AUGER-FAB.COM)

