

# ALL-FILL®, AMS, MATEER-BURT, & SPEE-DEE FUNNELS

Straight funnels are generally used with free flowing products, straight augers, and often include use of a Collector Funnel (see Form 658). Lip funnels are used with non free-flowing products and self-feeding augers. Use this page to specify and order new, spare, and replacement Straight and Lip Funnels for augers and filling machines from All-Fill, Inc.®, Mateer-Burt, AMS, and Spee-Dee. Refer to Form 654 for Funnels used with Mateer-Burt Neutron auger fillers.

## DIMENSIONS & SPECIFICATIONS

**SIZE:**

- 3 1/2" Hub (Augers 4-32)
- 4" Hub (Augers 34-52)

**GROUP:**

- Group 1: Straight
- Group 2: Lip
- Group 3: Threaded

A: \_\_\_\_\_

B: \_\_\_\_\_

C: \_\_\_\_\_

D: \_\_\_\_\_

E: \_\_\_\_\_

F: \_\_\_\_\_

### 3 1/2" Hub (Augers #4-#32)

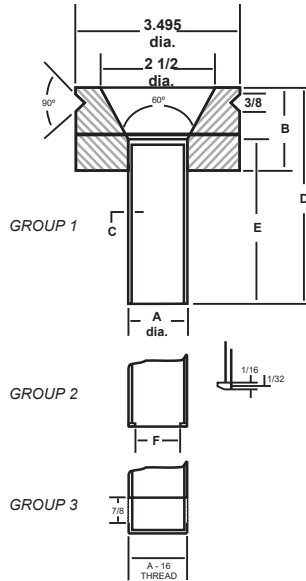

### 4" Hub (Augers #34 - #52)

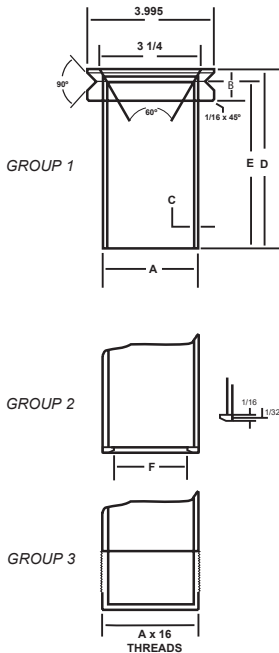

4102 Edges Mill Road, Downingtown, PA 19335 USA  
 Phone (610) 524-3350 Fax (610) 363-2821  
 Toll Free: 800-334-1529 info@auger-fab.com  
**WWW.AUGER-FAB.COM**

